



PNEUMATIC TOOLS

**Safety, Operation
and Maintenance**



**PANEL
SAWS**

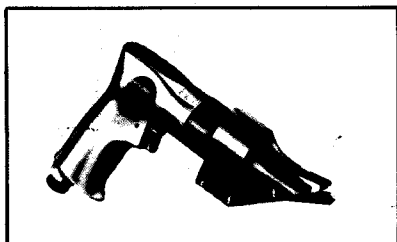

**POWER
SHEARS**

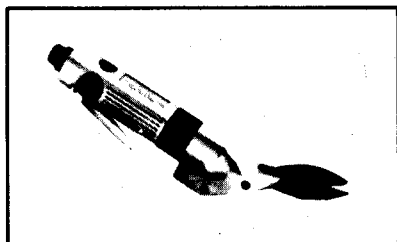

**SCISSOR
SHEARS**

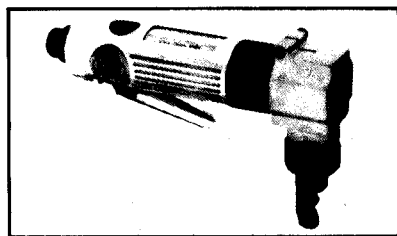

**POWER
NIBBLER**



5055 Madison Road • Cincinnati, Ohio 45227 • (513) 271-0333

Safety Rules

Keep Work Area Clean

Cluttered areas and benches invite accidents.

Keep Children Away

All visitors should be kept safe distance from work area.

Store Idle Tools

When not in use, tools should be stored in dry, high or locked-up place—out of reach of children.

Don't Force Tool

It will do the job better and safer at the rate for which it was designed.

Use Right Tool

Don't force a small tool to do the job of a heavy duty tool.

Wear Proper Apparel

No loose clothing or jewelry to get caught in moving parts. Rubber gloves and footwear are recommended when working outdoors.

Use Safety Glasses

Use safety glasses with most tools. Also face or dust mask if cutting operation is dusty.

Secure Work

Use clamps or a vise to hold work, it's safer than using your hand and it frees both hands to operate tool.

Don't Overreach

Keep proper footing and balance at all times.

Maintain Tools with Care

Keep tools sharp and clean for best and safest performance. Follow instructions for lubricating and changing blades.

Disconnect Tools

When not in use; before servicing; when changing blades.

Remove Adjusting Keys and Wrenches

Form habit of checking to see that keys and adjusting wrenches removed from tool before turning it on.

Avoid Accidental Starting

Don't carry connected tool with finger on trigger. The tool should be used only for the purpose for which it is designed.

Read Operating Instructions Carefully.

Operating Instructions

PANEL SAWS

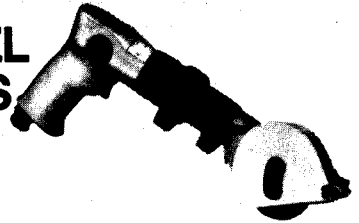

Be sure the work piece is securely held unless it will remain secure due to its own weight or bulk. Grasp the tool with both hands, one around the handle where the trigger switch is located, the other around the neck or sleeve which holds the cutting head in position. Before starting the motor, place the shoe of the foot at the edge of the material to be cut.

Make certain the saw guard is set to depress to the desired depth. Be sure the shoe is flat or level and ready to make full contact with the surface to be cut. The scribed line to be cut should appear in the vee type guiseight on the saw guard.

Squeeze the trigger switch and set the blade in motion. Slowly push the saw forward until the blade makes contact and starts to cut. Gradually increase pressure until blade is cutting at full capacity at a uniform speed without the feel of being forced or slowing to a stall. Keep the blade perpendicular to the cut and the feed at a constant speed. Do not jerk or suddenly thrust tool in cut and do not rock tool from side to side so as to bind blade in the cut. When blade starts cutting it is more desirable to "crowd" rate of feed to attain efficient cutting speed rather than to hold back and permit the blade to "dwell" in the cut.

Shut off the power the moment the saw has completed the cut through the sheet. If the cut is to be ended within the boundary of the sheet, bring the saw up to the end of the cut, hold firmly, shut off the power and let it coast to a full stop. Then lift the saw from the cut. NEVER BACK UP THE SAW IN THE CUT WITH THE POWER ON AND THE BLADE IN MOTION. This is the most frequent cause of broken blades and can result in more serious damage to the tool.

For plunge cutting, that is, starting a cut within the perimeter or boundaries of a sheet see the explicitly detailed instructions in the operation and service manual.

Where conditions permit, blade life can be extended and cutting efficiency improved through the use of a lubricant such as a grease stick, wax or tallow, or even cutting oil. It is recommended to practice cutting with the KETT Saw on scrap material until a knack of using the tool is acquired.

POWER SHEARS

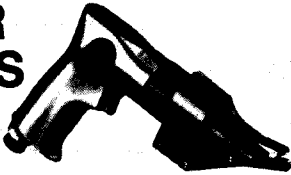

Please read carefully all safety rules and operating instructions. The Model P-500 and P-1060 Shears are recommended for CR sheet steel up to 18 gauge, the P-542 to 16 gauge, the P-540 to 14 gauge. Secure work piece. To start cut, place side knives of shear slightly on the top side of the edge of the work piece to steady the tool and ready it for the cut. Depress the trigger and guide shear into the work. Do not force it. Avoid double thicknesses of material which exceed the recommended capacity. For cutting within perimeter of work piece drill a $\frac{1}{2}$ " diameter starting hole and follow instructions above. If resistance to tool develops or cutting becomes difficult, discontinue cutting and check the following: lubrication; thickness of material; sharpness of cutting blades.

SCISSOR SHEARS

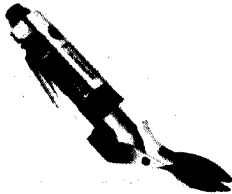

Read Safety Rules carefully, and observe all precautions. The KETT Scissors Shear is recommended for woven wood slat type shades; carpeting and carpet underlay or padding; Linoleum; vinyl and rubber flooring tile; soft, pliable plastic sheeting up to $\frac{1}{8}$ " thickness; and many other similar sheet like materials.

The Shear head can be rotated a full 360 degrees on the power unit making it possible to position it to cut in close quarters. This feature also serves to set the oscillating blade to a preferred position either to the top or to the bottom of the shear unit.

If resistance to tool develops or cutting becomes difficult, discontinue cutting and check the following: lubrication; thickness of material; sharpness of cutting blades. Blades can be sharpened.

The Model P-541 Scissor Shear is recommended for steel siding and other light gauge metals. Secure work piece. To start cut, place knives of shear slightly on the side of the work piece to steady the tool and ready it for the cut. Depress the trigger and guide shear into the work. Simply depress the trigger to adjust the speed to suit the material being cut. Do not force it.

POWER NIBBLER

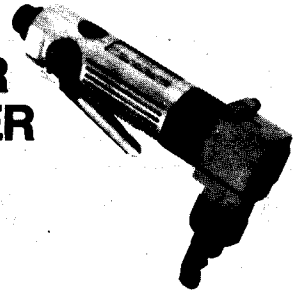

Please read carefully all safety rules and operating instructions.

The PN-1000 Nibbler is recommended for CR sheet steel up to 18 gauge. Secure work piece. To start cut, place die opening of nibbler slightly onto the edge of the work piece to steady the tool and ready it for the cut. Depress the trigger switch on the drive motor and guide the nibbler into the work. Don't force it. Avoid double thickness of material which exceed the 18 gauge recommended capacity. For cutting within perimeter of work piece, drill a $\frac{3}{16}$ " diameter starting hole and follow instructions above. If resistance to tool develops or cutting becomes difficult, discontinue cutting and check the following: lubrication; chip clogging; thickness of material; sharpness of punch and die.

Maintenance

When servicing use only identical replacement parts.

Tool may be cleaned and lubricated by the user but any other servicing should be performed by the manufacturer or any authorized representative or service station.

Loss of power or erratic action

If resistance to tool develops or cutting becomes difficult, discontinue cutting and check the following: lubrication, thickness of material; sharpness of cutting blades; air pressure.

Check for low air pressure or air line restrictions, also reduced compressor output or excessive drain on air lines.

Dirt and gum deposits in tool may cause loss of power and may be removed by flushing tool with a rust inhibitive oil.

For maximum efficiency, 90 psi of clean, dry air should be supplied at the tool during operation. Use of one horsepower or larger compressor connected to an air tank of at least 40 gallons capacity is recommended.

Pipe and fittings between compressor and air hose outlets should be $\frac{1}{2}$ " pipe size ($\frac{5}{8}$ " ID). Air hose should be at least $\frac{3}{8}$ " ID.

LUBRICATION

Lubricate the air motor daily with a good grade of air motor oil. Use a continuous air-line oiler with filter.

RIGHT ANGLE DRILL & SAW HEADS



Saw and drill head gears should be lubricated after 25 to 30 hours use. Inject a light cup grease into the grease opening covered by screw plug 181-2 in the bottom of the geared right angle transmission head. Tubes of grease are available from stock. Specify 264-1 tube grease for lubrication.

Adherence to these maintenance instructions will greatly increase the life of your saw so it will give you long and satisfactory service.

SHEAR HEADS



Once every three months, depending upon usage, remove the Shear Head from the power unit following the instructions given on the service sheet under the heading "Disassembly—To remove the shear head assembly from the drive motor." Put a few drops of heavy oil on the Eccentric Bearing Assembly so that it saturates the needle bearing. Grease is even better if it can be forced or pressed into the needle bearing.

NIBBLER HEAD



When servicing use only identical replacement parts. Once every three months, depending upon usage, remove the nibbler head from the power unit by loosening clamping screw (M133-36) and pull the head with a twisting action. Lubricate bearing surface of the eccentric nut (41-24-1) with a good grade of bearing grease. Place nibbler head back onto motor unit. Eccentric nut must engage with the link assembly as head is placed onto motor. Tighten clamping screw snugly to lock head assembly in place.

ALL ANGLE HEAD



To lubricate the 360° All Angle Head, first separate the two halves of the head by removing the socket head swivel stud out of the swivel stud nut. With the two halves separated, fill the drive spindle side until level, with 264-1 Tube Grease.

Be sure to replace the copper shim between the two halves of the head. After the two halves are tightly clamped together, remove the excess grease. The tool is again ready for use.



A FAMILY OF KETT AIR TOOLS

POWER UNIT

+ CUTTING HEAD = KETT MODEL NUMBER

Pneumatic,
90 PSI, 4 CFM,
2200 RPM,
air inlet 1/4"
NPT

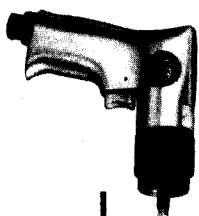

Pistol Grip
253-57



Straight Handle
253-56

154-54	+		+	170-25	+		+	567-1A	+		+	KS-21	=	PS-521 Pneumatic Saw Capacity 18 Gauge Steel 1/4" Plastic		
154-54	+		+	170-25	+		+	567-2A	+		+	KS-26	=	PS-526 Pneumatic Saw Capacity 16 Gauge Mild Steel		
154-50	+		+	60-25	+		+	41-24	+		+	41-20H	=	P-541 Pneumatic Scissors Capacity 24 Gauge Steel Sliding		
154-50	+		+	60-25	+		+	40-24	+		+	40-20H	=	P-540 Pneumatic Shears Capacity 14 Gauge Mild Steel		
154-50	+		+	60-25	+		+	40-24	+		+	42-20H	=	P-542 Pneumatic Shears Special Order Capacity 16 Gauge Mild Steel		
154-50	+		+	60-25	+		+	60-24	+		+	60-20H	=	P-1060 Straight Shears Capacity 18 Gauge Mild Steel		
154-50	+		+	60-25	+		+	60-24	+		+	80-20H	=	P-1080 Straight Scissors Capacity Only Pliable Materials		
154-47	+		+	41-24-1	+		+	1020	=					PN-1000 Pneumatic Nibblers Capacity 18 Gauge Mild Steel Special Order		
154-54	+		+	250-5	=									PD-1001 Straight Drill Capacity 1/4" Capacity Special Order		
154-54	+		+	170-25	+		+	567-1A	+		+	KU-5	=	PD-1005 All Angle Drill Capacity 1/4" Capacity Special Order		
154-54	+		+	170-25	+		+	567-1A	+		+	KRA-6	+	250-5	=	PD-1006 Right Angle Drill Capacity 1/4" Capacity Special Order

KETT

Model 1020 Nibbler Attachment

Safety, Operation and Maintenance

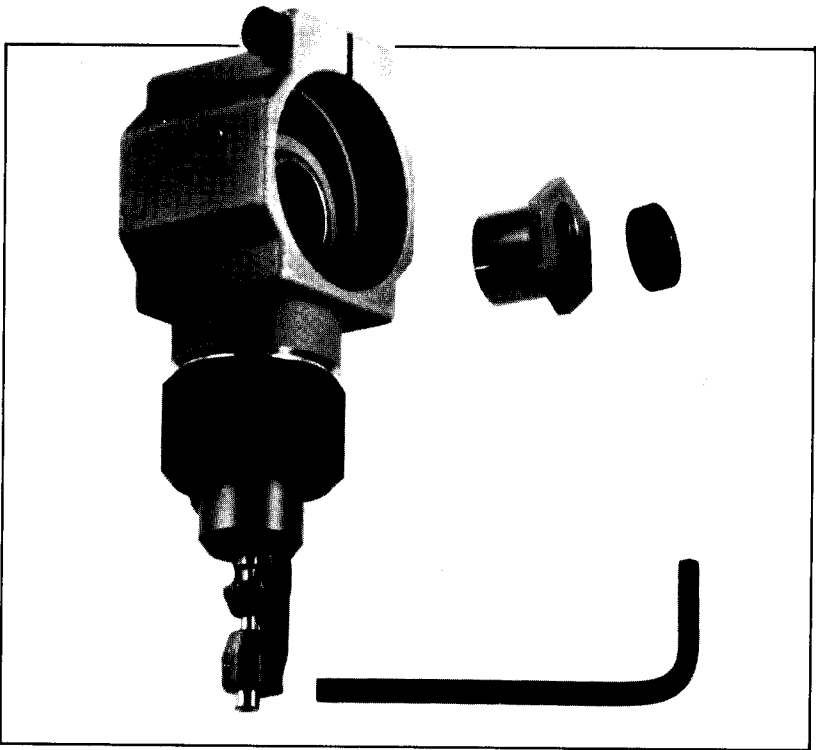

Fits all KETT Shear motors and is also interchangeable with other 40-20 and 60-20 compatible shear heads.

Safety Rules

Keep Work Area Clean—Beware of Metal Chips

Cluttered areas and benches invite accidents. Metal chips may inflict injury.

Keep Children Away

All visitors should be kept a safe distance from work area.

Store Idle Tools

When not in use, tools should be stored in dry, high or locked-up place—out of reach of children.

Don't Force Tool

It will do the job better and safer at the rate for which it was designed.

Use Right Tool

Don't force a small tool to do the job of a heavy duty tool.

Wear Proper Apparel

No loose clothing or jewelry to get caught in moving parts. Rubber gloves and footwear are recommended when working outdoors when power is electric.

Use Safety Glasses

Use safety glasses. Also face or dust mask if cutting operation is dusty.

Secure Work

Use clamps or a vise to hold work. It's safer than using your hand and it frees both hands to operate tool.

Don't Overreach

Keep proper footing and balance at all times.

Maintain Tools With Care

Keep tools sharp and clean for best and safest performance. Follow instructions for lubricating and changing punch or dies.

Disconnect Tools

When not in use; before servicing; when changing punch or die.

Remove Adjusting Keys and Wrenches

Form habit of checking to see that keys and adjusting wrenches are removed from tool before turning it on.

Avoid Accidental Starting

Don't carry connected tool with finger on trigger. The tool should be used only for the purpose for which it is designed.

Read Operating Instructions Carefully.

Assembly

To assemble Nibbler Head (1020) onto drive motor.

1. Insert spacer (154-47 or 154-57) onto shaft of motor.
2. Turn eccentric nut (41-24-1) onto shaft with hex side toward motor and against spacer.
3. Lubricate bearing surface of eccentric nut (41-24-1) with a good grade of bearing grease.
4. Place nibbler head onto motor unit. Eccentric nut (41-24-1) must engage with link assembly (1024) as head is placed onto motor unit.
5. Tighten clamping screw (M133-36) snugly to lock head assembly in place.

Adjustments

The die (1021) rotates a full 360 degrees. To change position, loosen clamp nut (1029), set die in desired position, tighten clamp nut. When cutting corrugated metal, set die at 90 degrees to the motor unit. This will allow the motor and head to roll with the corrugations.

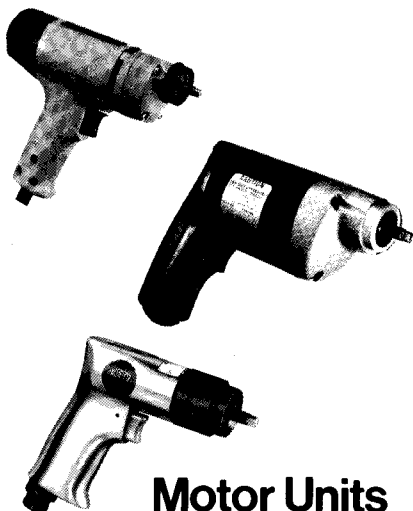

Motor Units

Operating Instructions

Please read carefully all safety rules and operating instructions.

The 1020 Nibbler Head is recommended for CR sheet steel up to 18 gauge. Secure work piece. To start cut, place die opening of nibbler slightly onto the edge of the work piece to steady the tool and ready it for the cut. Depress the trigger switch on the drive motor and guide the nibbler into the work. Don't force it. Avoid double thickness of material which exceed the 18 gauge recommended capacity. For cutting within perimeter of work piece, drill a 1/2" diameter starting hole and follow instructions above. If resistance to tool develops or cutting becomes difficult, discontinue cutting and check the following: lubrication; chip clogging; thickness of material; sharpness of punch and die.

Wear Safety Goggles

Always beware of metal chips which may inflict injury.

To Change Punch and/or Die

1. Disconnect motor unit from power source.
2. Remove clamp nut (1029) and the die (1021) will slide off.
3. Remove retainer nut (1027) and the punch (1022) will slide out of the head.
4. Insert new punch (1022) into head and secure with retainer nut (1027).
5. Insert new die (1021) and secure with clamp nut (1029).

Maintenance of 1020 Nibbler Head

When servicing use only identical replacement parts. Once every three months, depending upon usage, remove the nibbler head from the power unit by loosening clamping screw (M133-36) and pull the head with a twisting action. Lubricate bearing surface of the eccentric nut (41-24-1) with a good grade of bearing grease. Place nibbler head back onto motor unit. Eccentric nut must engage with the link assembly as head is placed onto motor. Tighten clamping screw snugly to lock head assembly in place.

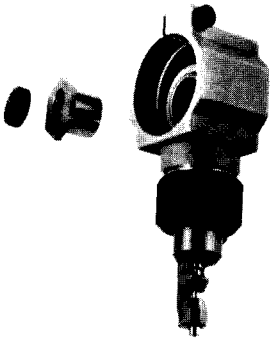

Nibbler Head

Shear Head

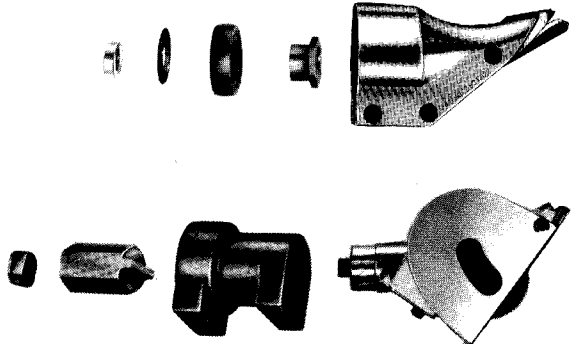

Saw Head

Model 1020 Nibbler Attachment

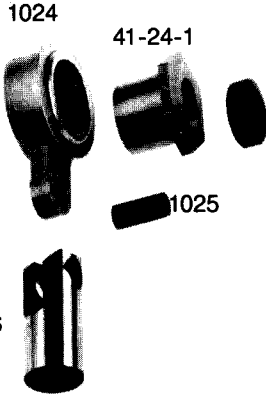
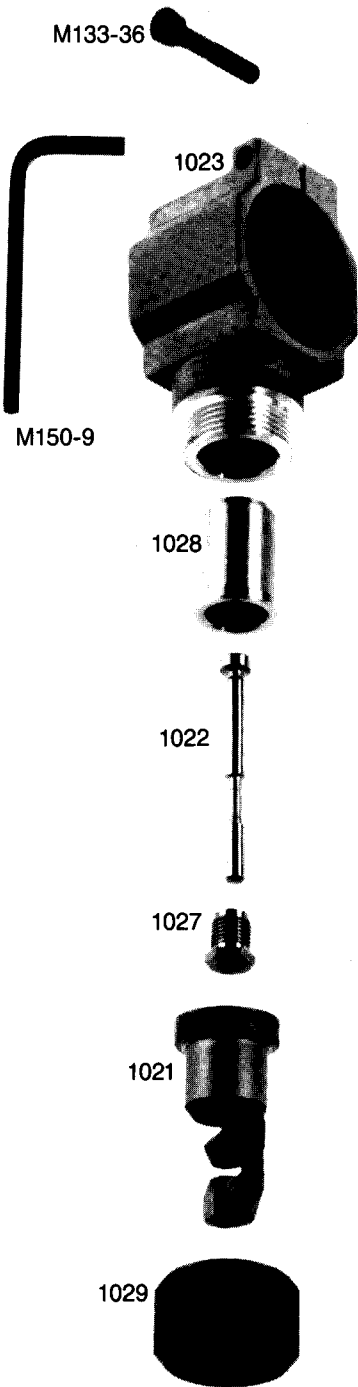

Spacer _____
see note on spacer
envelope for proper
thickness and record
number

1020 Parts List

41-24-1	Eccentric Nut
1021	Die
1022	Punch
1023	Nibbler Housing
1024	Link Assembly
1025	Pin
1026	Plunger
1027	Retainer Nut
1028	Brass Sleeve
1029	Clamp Nut
M133-36	Clamping Screw
M150-9	4mm Socket Key
154-47	Spacer (.181" Thick)
154-57	Spacer (.142" Thick)

NOT SHOWN

264-5	Stick Cutting Wax
-------	-------------------

The use of Stick Cutting Wax (264-5) or a cutting oil will greatly improve the performance of the KETT Nibbler. Use stick cutting wax on the underside of the work piece for best results.



The Kett Tool Company
5055 Madison Road • Cincinnati, Ohio 45227
(513) 271-0333